

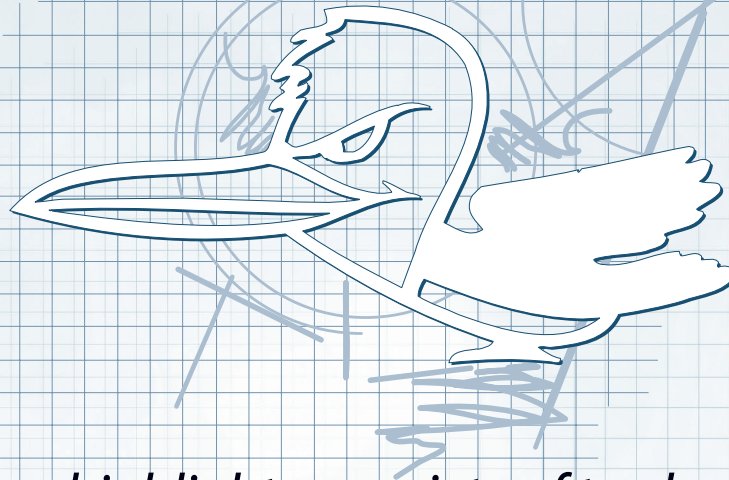

RED HEAD®

Fastening Applications Guide



This section highlights a variety of trade applications and provides information that will assist you in selecting the best fastening system for your application.

While these are not to be considered complete, they will give you an idea of how contractors use our products.

For example, on the Electrical Contractor page, you will find applications, such as junction box/panel boards and

suspended lighting. Next to the diagrams are the product name(s) and page number in this catalog where you will find complete information on these products needed for that particular application.

Curtain Wall Applications

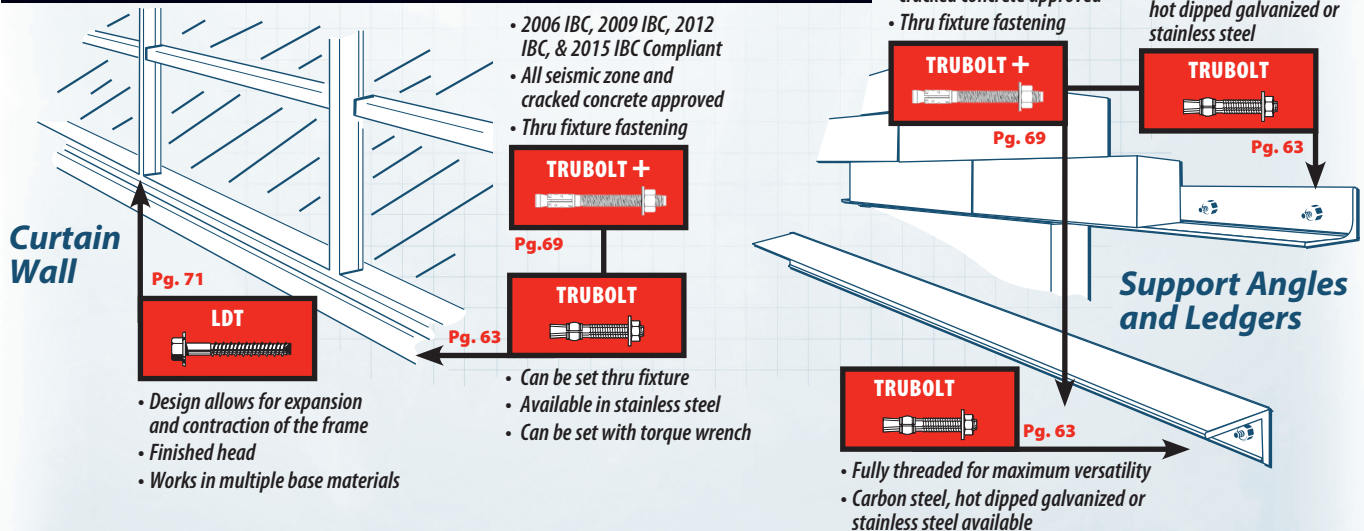

For seismic recognition, see ICC-ES evaluation reports.

For installation guidelines for your application, please contact our Technical Services Department at 1-800-848-5611.

ITW Red Head®

Call our toll free number 800-848-5611 or visit our web site for the most current product and technical information at www.itwredhead.com



RED HEAD®

Electrical Contractor Applications



Pg. 100

- Simple to install
- Drill hole, hammer into hole

Junction Box/ Panel Boards



Pg. 88

- Counter sunk flathead style for flush installation
- Works in concrete or block
- Available in 3/16" and 1/4" diameters

Conduit Clip

Pg. 100



- Simple to install
- Drill hole, hammer into hole

- Available in special 3/8" version for precast planks
- Available in sizes 1/4" thru 3/4" internal thread diameters



Pg. 80

Suspended Lighting

- 2006 IBC, 2009 IBC, 2012 IBC, & 2015 IBC Compliant
- All seismic zone and cracked concrete approved
- Used with Rod Coupler

- Used with rod coupler
- 1/4" to 1" diameters



Pg. 63



Pg. 69

Transformers Switch Gear Electrical Enclosures

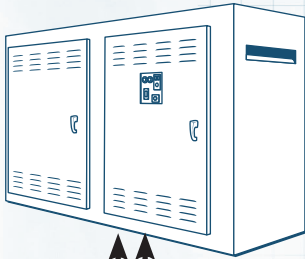

Pg. 63

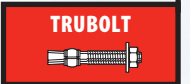

- Available in carbon, hot dipped galvanized, 304 and 316 stainless steel

Pg. 69



- 2006 IBC, 2009 IBC, 2012 IBC, & 2015 IBC Compliant
- All seismic zone and cracked concrete approved
- Thru fixture fastening

Unistrut-Cable Tray/Conduit

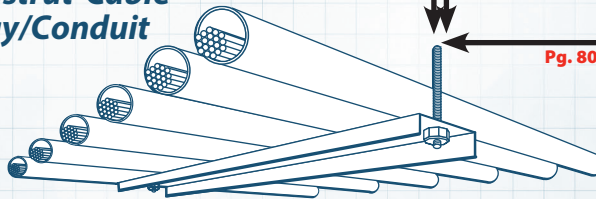

Pg. 80



- Available in special 3/8" version for precast planks
- Available in sizes 1/4" thru 3/4" internal thread diameters

- Ideal for closely spaced groups of anchors



Pg. 23

Light Standards Poles

Pg. 39/46



- "Stress Free" anchor—can be used close to edges or in close spacing pattern



Pg. 85

- Counter sunk and threshold head styles also available
- Works in concrete, block and brick

Wall Mounted Lighting

Pg. 71



- Works in solid concrete, hollow block and brick
- Cuts a thread into the mounted surface
- Finished head appearance



Pg. 80

Suspended Pipe or Conduit

For seismic recognition, see ICC-ES evaluation reports.

For installation guidelines for your application, please contact our Technical Services Department at 1-800-848-5611.

Mechanical Contractor Applications

NOTE:

C6+ and G5 both can be used for oversized holes when repairing pumps and machinery anchoring.

Machinery and Equipment

Pg. 71



• Removable

Pg. 39/46



- High Load Capacity
- Suitable for use close to edge of slab
- Ideal for moderate to hot climates
- Can be used for oversized holes

Pg. 23



- Vibration resistant
- Quick-Cure

Pumps

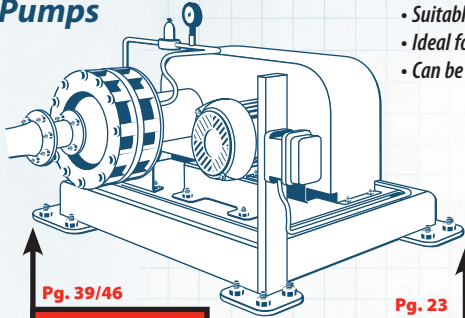

Pg. 39/46



- Corrosion resistant
- Vibration resistant
- NSF Approved

Pg. 23



- Quick-Cure
- Vibration Resistant

- Carbon, hot dipped galvanized, 304 and 316 stainless steel
- 1/4" to 1" diameters

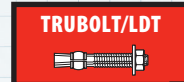

Pg. 63/71

- Simple to install—drill hole and screw in
- Fire resistant



Pg. 88

Ductwork/HVAC



Heavy-Duty Pipe Support

- 2006 IBC, 2009 IBC, 2012 IBC, & 2015 IBC Compliant

- All seismic zone and cracked concrete approved

- Thru fixture fastening

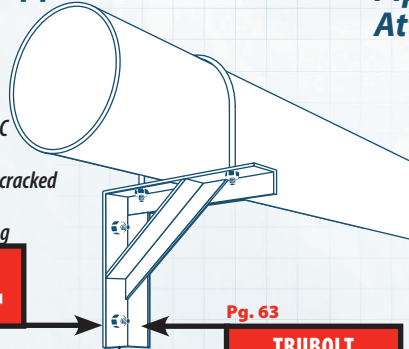

Pg. 69

Pg. 63



- Carbon, hot dipped galvanized, 304 and 316 stainless steel
- 1/4" to 1" diameters

Pg. 39/46



- High load capacity
- Corrosion resistant
- NSF Approved

Pipe/Strut Attachment

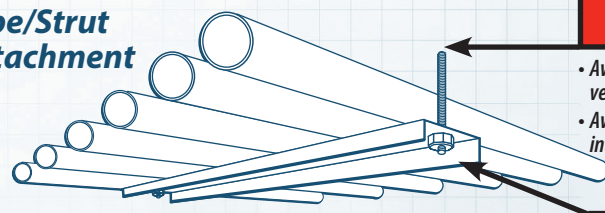

MULTI-SET DROP-IN

- Available in special 3/8" & 1/2" version for prestressed concrete
- Available in 1/4" thru 3/4" internal thread diameters

Pg. 63

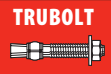

- Available in carbon, hot dipped galvanized, 304 and 316 stainless steel

- Available in special 3/8" & 1/2" version for prestressed concrete
- Available in 1/4" thru 3/4" internal thread diameters



Pg. 80

Pipe Support, Fire Sprinkler

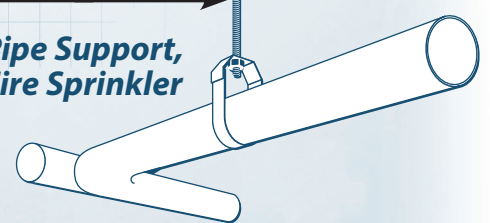

For seismic recognition, see ICC-ES evaluation reports.

For installation guidelines for your application, please contact our Technical Services Department at 1-800-848-5611.

Drywall Contractor & Carpenter Applications

Window and Door Frames

DYNABOLT

Pg. 85



- Counter sunk and threshold head styles
- Works in concrete, block and brick

TAPCON

Pg. 88



- Works in solid and hollow base material
- Removable
- Can be set flush with Phillips head if counter sunk

Drywall Track

Ceiling Track

Floor Track

Pg. 88

TAPCON



- Simple to use—drill hole and screw in
- Setting tool (C1000) available for tight spaces

Pg. 88

TAPCON



- Counter sunk flathead style for flush installation
- Works in concrete or block
- Available in 3/16" and 1/4" diameters

Furring Strips

- Drill hole, install by hand or impact wrench

LDT

Pg. 71



Framing/Sill Plating

TRUBOLT

Pg. 63

- Full threaded for maximum versatility
- Metro-Dade Approved
- Other approvals on page 66

Pg. 69

TRUBOLT +

- 2006 IBC, 2009 IBC, 2012 IBC, & 2015 IBC Compliant
- All seismic zone and cracked concrete approved
- Thru fixture fastening

Pg. 39/46

C6+/G5 ADHESIVE

- High load capacity
- Corrosion resistant
- NSF Approved
- Used for slower cure projects

Pg. 23

A7+ ADHESIVE

- Fast cure
- Works in damp wet conditions
- Use A7+ with threaded rod for this application

DYNABOLT

Pg. 85



- Counter sunk and threshold head styles
- Works in concrete, block and brick

For seismic recognition, see ICC-ES evaluation reports.

For installation guidelines for your application, please contact our Technical Services Department at 1-800-848-5611.

Acoustical Ceiling Installer

Applications

- Single piece design
- Drill hole, hammer wedge into hole, pull down with claw hammer

TIE WIRE WEDGE



- Tapcon used with angle clip
- Simple to use, drill hole and drive Tapcon

TAPCON



Pg. 88

Pg. 85

DYNABOLT TIE WIRE



- 9/32nd hole
- Ideal for concrete brick, and block
- Carbon steel

Acoustical Ceiling

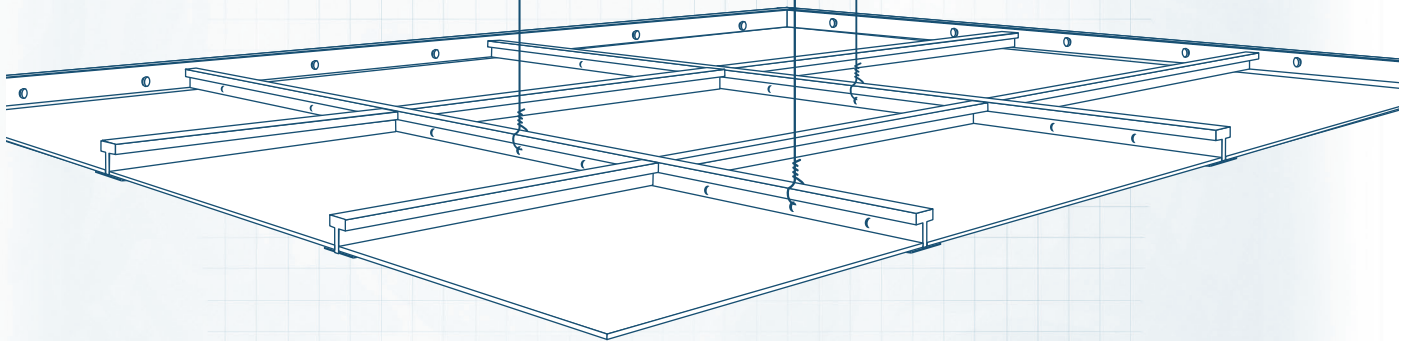

For seismic recognition, see ICC-ES evaluation reports.

For installation guidelines for your application, please contact our Technical Services Department at 1-800-848-5611.

ITW Red Head

Call our toll free number 800-848-5611 or visit our web site for the most current product and technical information at www.itwredhead.com

 **RED HEAD**

Steel Erector Applications

Steel Beams/Columns

Pg. 39/46

C6+/G5 ADHESIVE

- Longer working time for positioning of steel
- Can be used in oversized holes
- Works in wet/damp conditions

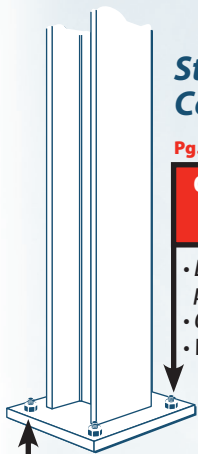

Pg. 63

TRUBOLT

- Full threaded for maximum versatility
- Metro-Dade Approved
- Other approvals on page 66

Pg. 23

A7+ ADHESIVE

- Ideal for closely spaced groups of anchors

Stairs and Ladders

- 2006 IBC, 2009 IBC, 2012 IBC, & 2015 IBC Compliant
- All seismic zone and cracked concrete approved
- Thru fixture fastening

TRUBOLT +



Pg. 69

TRUBOLT

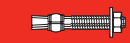

Pg. 63

- Can be set thru fixture
- Fast and immediate loading



Pg. 23

A7+ ADHESIVE



- Fast cure
- Works in damp wet conditions
- Use A7 with threaded rod for this application

Pg. 71

LDT



- Finished head
- Removable
- For use in concrete

Ornamental Iron

DYNABOLT



Pg. 85

- Multiple head styles
- Ideal for concrete, brick and block
- Carbon and stainless steel

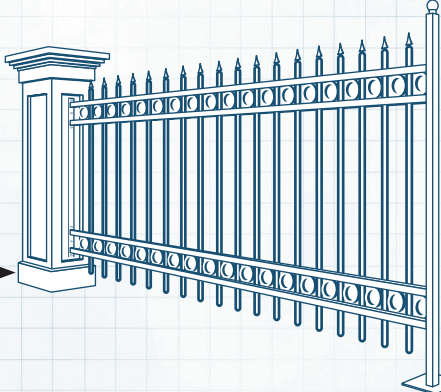

Pg. 23

A7+ ADHESIVE



- Fast cure
- Works in damp wet conditions
- Use A7 with threaded rod for this application

Hand Railings

Protective Railings and Fencing

TRUBOLT

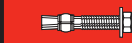

Pg. 63

- Full threaded for maximum versatility
- Metro-Dade Approved
- Other approvals on page 66

Pg. 23

A7+ ADHESIVE



- Quick cure
- Works in damp wet conditions
- Works in concrete & masonry

DYNABOLT



Pg. 85

- Multiple head styles
- Ideal for concrete, brick and block
- Carbon and stainless steel

TRUBOLT +



Pg. 69

- 2006 IBC, 2009 IBC, 2012 IBC, & 2015 IBC Compliant
- All seismic zone and cracked concrete approved
- Thru fixture fastening

Pg. 71

LDT



- Finished head
- Removable
- For use in concrete

For seismic recognition, see ICC-ES evaluation reports.

For installation guidelines for your application, please contact our Technical Services Department at 1-800-848-5611.

Concrete & Masonry Contractor Applications

Concrete Block Reinforcement

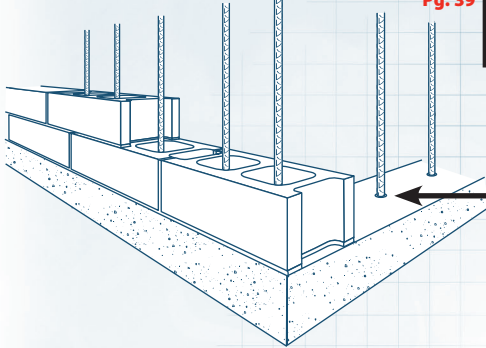

- NSF /ANSI 61
- Vibration resistant
- Corrosion resistant

- Slow curing adhesive—ideal for moderate to hot climates

Pg. 39



Pg. 46



Rebar Doweling

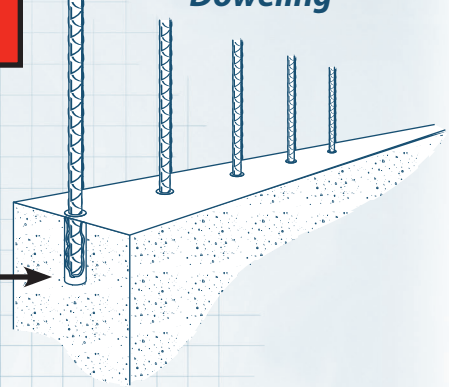

Pg. 23



- Fast curing adhesive—ideal for moderate to cold climates

Stone Attachment

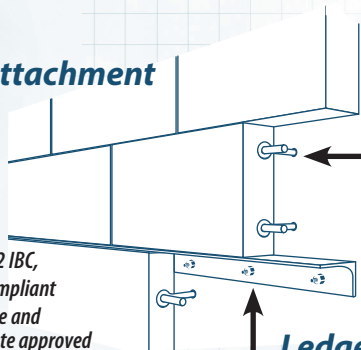

- 2006 IBC, 2009 IBC, 2012 IBC, & 2015 IBC Compliant
- All seismic zone and cracked concrete approved
- Thru fixture fastening

Pg. 63

Ledger Angle Attachment



Pg. 69



- Fully threaded for maximum versatility
- Available in carbon, hot dipped galvanized and stainless steel

Brick Pinning

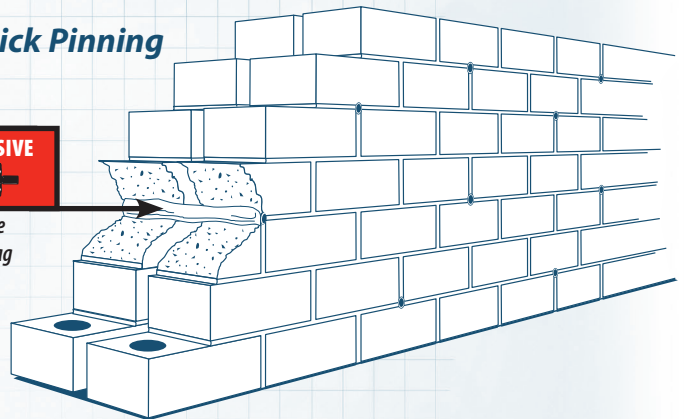

Pg. 23



- Compact space
- No-drip—no sag formula
- Easy clean up

Stone Attachment

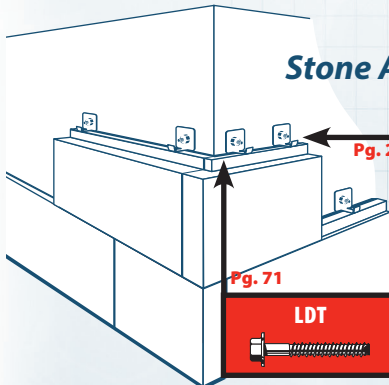

Pg. 23



- High load capacity in concrete block
- No drip—no sag formula
- Easy clean up

Pg. 71



- Finished head
- Removable
- For use in concrete

Concrete Formwork

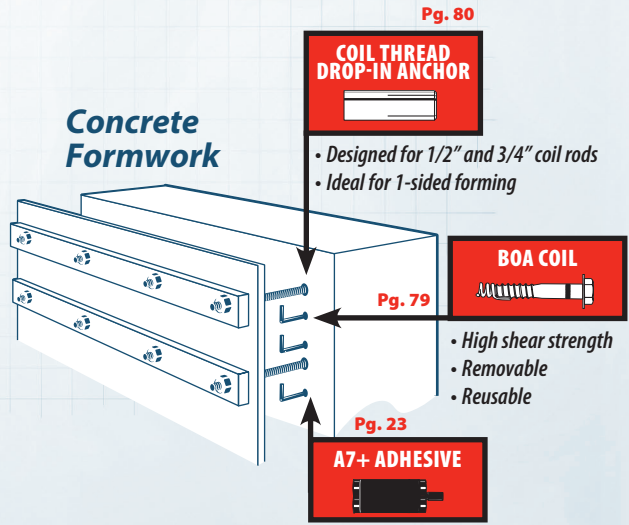

Pg. 80



- Designed for 1/2" and 3/4" coil rods
- Ideal for 1-sided forming

Pg. 79



- High shear strength
- Removable
- Reusable

Pg. 23



- Fast curing adhesive for rebar doweling

For seismic recognition, see ICC-ES evaluation reports.

For installation guidelines for your application, please contact our Technical Services Department at 1-800-848-5611.

ITW Red Head

Call our toll free number 800-848-5611 or visit our web site for the most current product and technical information at www.itwredhead.com

RED HEAD

Water & Waste Water Treatment Applications

Weirs and Gates

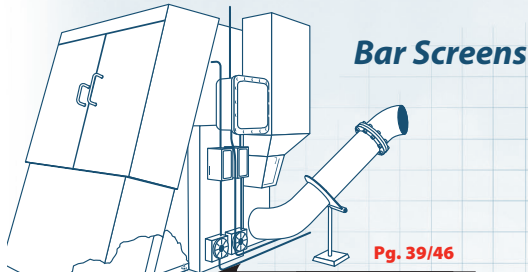

Bar Screens

Covers and Domes

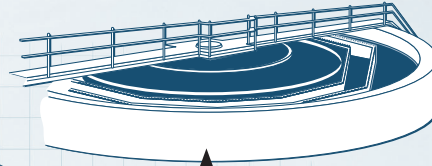

A7+ ADHESIVE

- Fast dispensing, fast curing adhesive
- Works in wet conditions
- NSF Approved

C6+/G5 ADHESIVE

- NSF/ANSI 61
- Vibration resistant
- Corrosion resistant

C6+/G5 ADHESIVE

- NSF/ANSI 61
- Vibration resistant
- Corrosion resistant

A7+ ADHESIVE

- Fast dispensing, fast curing adhesive
- Works with epoxy coated dowels

Railings and Ladders

C6+/G5/A7+ ADHESIVE

- NSF/ANSI 61
- Vibration resistant
- Install close to edge

TRUBOLT

- Heavy duty
- 360° hole contact
- 304 and 316 stainless steel

TRUBOLT +

- 2006 IBC, 2009 IBC, 2012 IBC, & 2015 IBC Compliant
- All seismic zone and cracked concrete approved
- Thru fixture fastening

Instrumentation and Controls

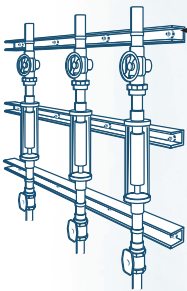

TRUBOLT

- Multiple head styles
- Heavy duty
- 304 and 316 stainless steel

TRUBOLT +

- 2006 IBC, 2009 IBC, 2012 IBC, & 2015 IBC Compliant
- All seismic zone and cracked concrete approved
- Thru fixture fastening

Pipe Supports

- Special 3/8" version for prestressed concrete
- Available in 1/4" thru 3/4" internal diameters
- Stainless steel available

MULTI-SET

TRUBOLT +

TRUBOLT

- Multiple head styles
- Heavy duty
- 360° hole contact
- 304 and 316 stainless steel

Conveyors

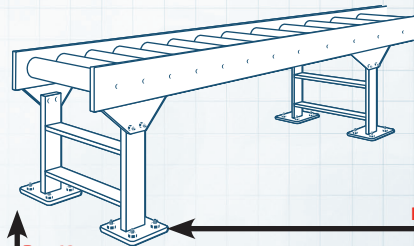

LDT

- Finished head
- Removable
- Install by hand or with impact wrench

TRUBOLT

- Fully threaded for maximum versatility
- Available in 304, 316 stainless, carbon, and galvanized steel

TRUBOLT +

- 2006 IBC, 2009 IBC, 2012 IBC, & 2015 IBC Compliant
- All seismic zone and cracked concrete approved
- Thru fixture fastening

Diffusers

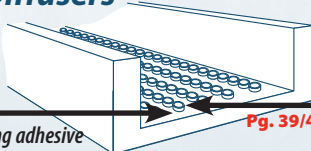

- NSF/ANSI 61
- Vibration resistant
- Corrosion resistant
- Can be installed underwater

A7+ ADHESIVE

- Fast dispensing, fast curing adhesive
- Works with epoxy coated dowels
- NSF Approved

C6+/G5 ADHESIVE

PUMPS

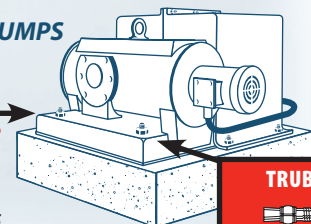

C6+/G5 ADHESIVE

- NSF/ANSI 61
- Vibration resistant
- Corrosion resistant
- Can be used in oversize holes

TRUBOLT

For seismic recognition, see ICC-ES evaluation reports.

For installation guidelines for your application, please contact our Technical Services Department at 1-800-848-5611.

Highway & Bridge Contractor Applications

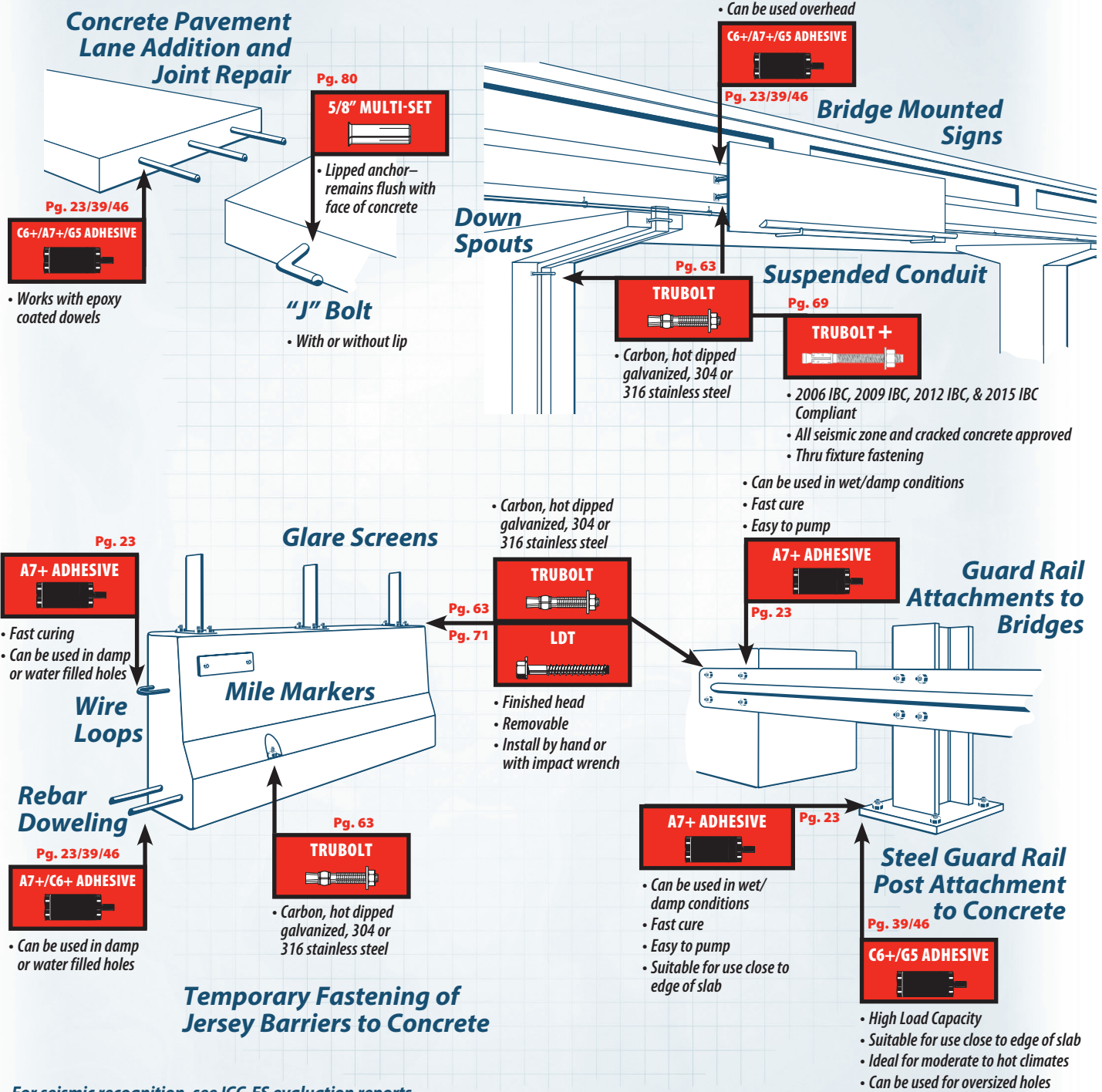

Department of Transportation Approvals & Listings

For approvals contact local engineering on a per project basis.
Call your local RED HEAD sales person for more information.



Call our toll free number 800-848-5611 or visit our web site for the most current product and technical information at www.itwredhead.com



General Contractor Applications

Replacement of Misplaced Anchors

Pg. 39/46

C6+/G5 ADHESIVE

- Ideal for hot climates—extended working time formula

Pg. 71

LDT

Pg. 23

A7+ ADHESIVE

- Damp holes or underwater
- Dispenses and cures faster in cold weather

Cast-In-Place Bolt in Wrong Location

Tilt Wall Anchorage

Pg. 79

BOA COIL

- High shear strength
- Removable
- Reusable

TRUBOLT

Pg. 63

- Available in 3/4" x 7"
- Drill hole deeper than anchor length, drive into hole after use

Pg. 69

TRUBOLT +

- 2006 IBC, 2009 IBC, 2012 IBC, & 2015 IBC Compliant
- All seismic zone and cracked concrete approved
- Thru fixture fastening

Seismic Hold Downs

- Damp holes or underwater
- Fastest cure (35 min. at 60°F)
- Dispenses and cures faster in cold weather

Pg. 23

A7+ADHESIVE

Pg. 23

A7+ ADHESIVE

- Damp holes or underwater
- Fastest cure (35 min. at 60°F)
- Dispenses and cures faster in cold weather

Replacement of Damaged Anchors

Pg. 39

C6+ ADHESIVE

- NSF Approved
- Vibration resistant
- Corrosion resistant
- Can be used in oversize holes

Pg. 39/46

C6+/G5 ADHESIVE

- Extended working time—ideal for warm to hot climates
- Can be used in oversize holes

Damaged Cast-In-Place Anchor

For seismic recognition, see ICC-ES evaluation reports.

For installation guidelines for your application, please contact our Technical Services Department at 1-800-848-5611.

Material Handling Applications

Overhead Doors

LDT
Pg. 71

- Hand installation block or concrete

A7+ ADHESIVE WITH UMBRELLA
Pg. 52

- High load in hollow block or concrete

Shelving

- Removable
- Easy to install
- Single piece design

LDT
Pg. 71

Pg. 63

TRUBOLT WEDGE

- Thru fixture fastening
- Available in hot-dipped galvanized steel, stainless steel

Pg. 69

TRUBOLT +

- 2006 IBC, 2009 IBC, 2012 IBC, & 2015 IBC Compliant
- All seismic zone and cracked concrete approved
- Thru fixture fastening

Conveyors

LDT
Pg. 71

- Finished head
- Removable
- Installs with impact wrench
- Single piece design

TRUBOLT WEDGE
Pg. 63

- Thru fixture fastening
- Installs fast with no spotting of holes

TRUBOLT +
Pg. 69

- 2006 IBC, 2009 IBC, 2012 IBC, & 2015 IBC Compliant
- All seismic zone and cracked concrete approved
- Thru fixture fastening

Rails

LDT
Pg. 71

- Finished head
- Removable
- Installs with impact wrench

Pg. 23

A7+ ADHESIVE

- Fast curing
- Impact resistant
- Non-sag formula

Pg. 23

A7+ ADHESIVE

- Fast curing
- Impact resistant
- Non-sag formula

Pg. 39/46

G6+/G5 ADHESIVE

- Extended working time—ideal for warm to hot climates
- Can be used in oversize holes

LDT
Pg. 71

- Finished head
- Removable
- Available with Envirex corrosion resistant high finish

Dock Bumpers

- 2006 IBC, 2009 IBC, 2012 IBC, & 2015 IBC Compliant
- All seismic zone and cracked concrete approved
- Thru fixture fastening

TRUBOLT +
Pg. 69

TRUBOLT WEDGE
Pg. 63

- Thru fixture fastening
- Installs fast with no spotting of holes

Racks

LDT
Pg. 71

- Finished head
- Removable
- Installs with impact wrench
- Single piece design

For seismic recognition, see ICC-ES evaluation reports.

For installation guidelines for your application, please contact our Technical Services Department at 1-800-848-5611.

Specialty Applications

Stadium Seating

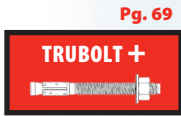
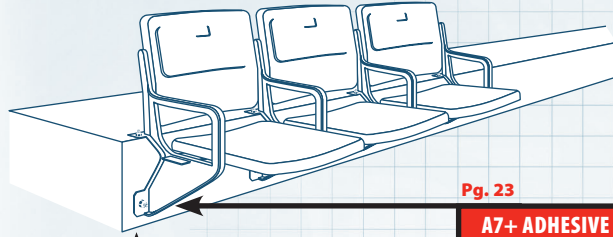

Pg. 69

- 2006 IBC, 2009 IBC, 2012 IBC, & 2015 IBC Compliant
- All seismic zone and cracked concrete approved
- Thru fixture fastening

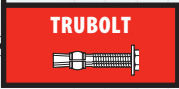

Pg. 63

- Corrosion resistant
- Normal weight or lightweight concrete
- Used in major stadiums across the country
- Immediate loading

Pg. 23

A7+ ADHESIVE



- Corrosion resistant
- Normal weight or lightweight concrete
- Used in major stadiums across the country

Basement Wrap

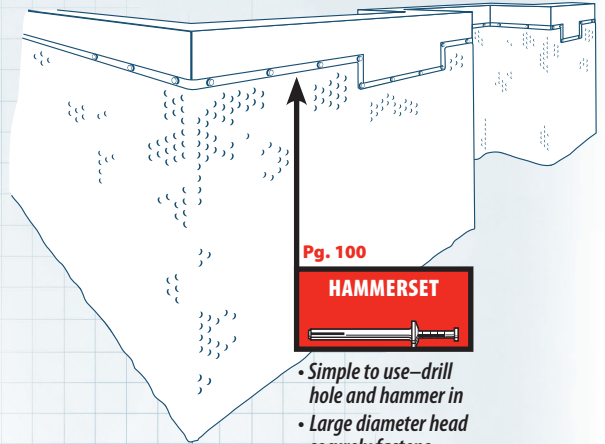

Pg. 100

HAMMERSET



- Simple to use—drill hole and hammer in
- Large diameter head securely fastens basement wrap

Expansion Joints

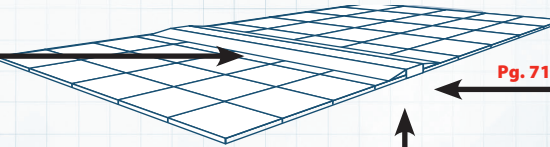

Pg. 69

- 2006 IBC, 2009 IBC, 2012 IBC, & 2015 IBC Compliant
- All seismic zone and cracked concrete approved
- Thru fixture fastening

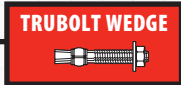

Pg. 63

- High load capacity
- Fast installation



Pg. 71

- Finished head
- Removable
- Installs by hand or with impact wrench

Pg. 39/46



- High load capacity
- Suitable for use close to edge of slab

Flooring Systems

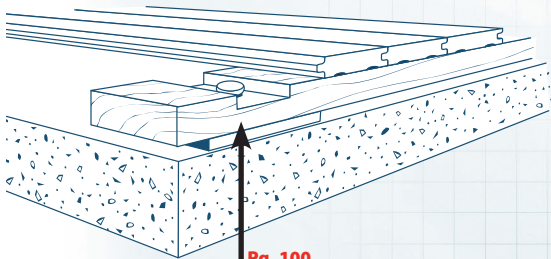

Pg. 100

HAMMERSET



- Simple to use—drill hole and hammer in

Underwater Installation

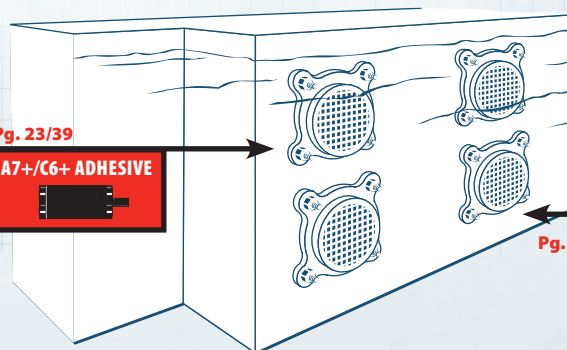

Pg. 23/39

A7+/C6+ ADHESIVE



- 2006 IBC, 2009 IBC, 2012 IBC, & 2015 IBC Compliant
- All seismic zone and cracked concrete approved
- Thru fixture fastening



Pg. 69



Pg. 63

- Vibration resistant
- Corrosion resistant
- Available in 316 stainless steel

For seismic recognition, see ICC-ES evaluation reports.

For installation guidelines for your application, please contact our Technical Services Department at 1-800-848-5611.